



DELTA-XERO

THE FUTURE IS SYSTEM RELIABILITY

DX1001-T-P

The DX modular housing arrangement offers a flexible and space conscious solution integrating our innovative DXO Cartridge to both new and existing systems. We provide up to 12 cartridges as a single unit in a compact and easily maintainable layout.

Pneumatic Driven System

The pneumatic driven unit can be supplied with a number of standard options to provide an effective conditioning package to suit the majority of systems. The flexibility of the unit allows tailoring to a customer's specific requirements.

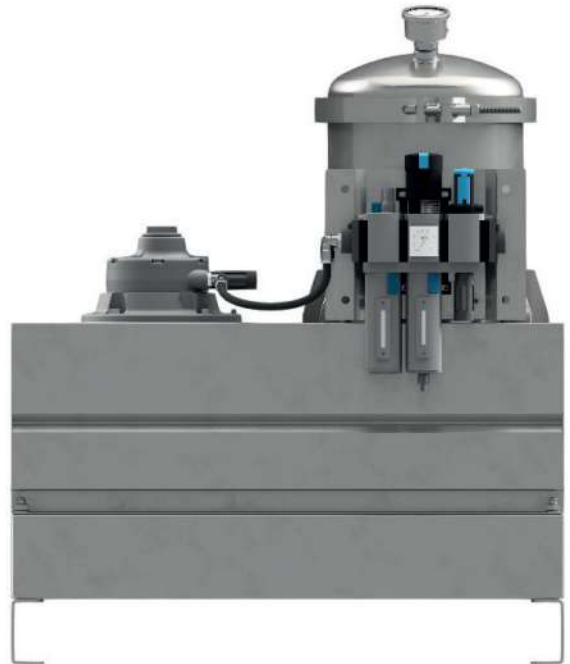

ایران - تهران - خیابان پاسداران بیست و هشتم
پلاک ۱ - برج آبتین، طبقه ۴ - واحد ۹
شماره تماس: ۰۲۱ ۷۳۶۴۰۰۰
info@rnaco.com



نماینده فروش و خدمات پس از فروش DELTA-XERO در ایران

Technical Specification

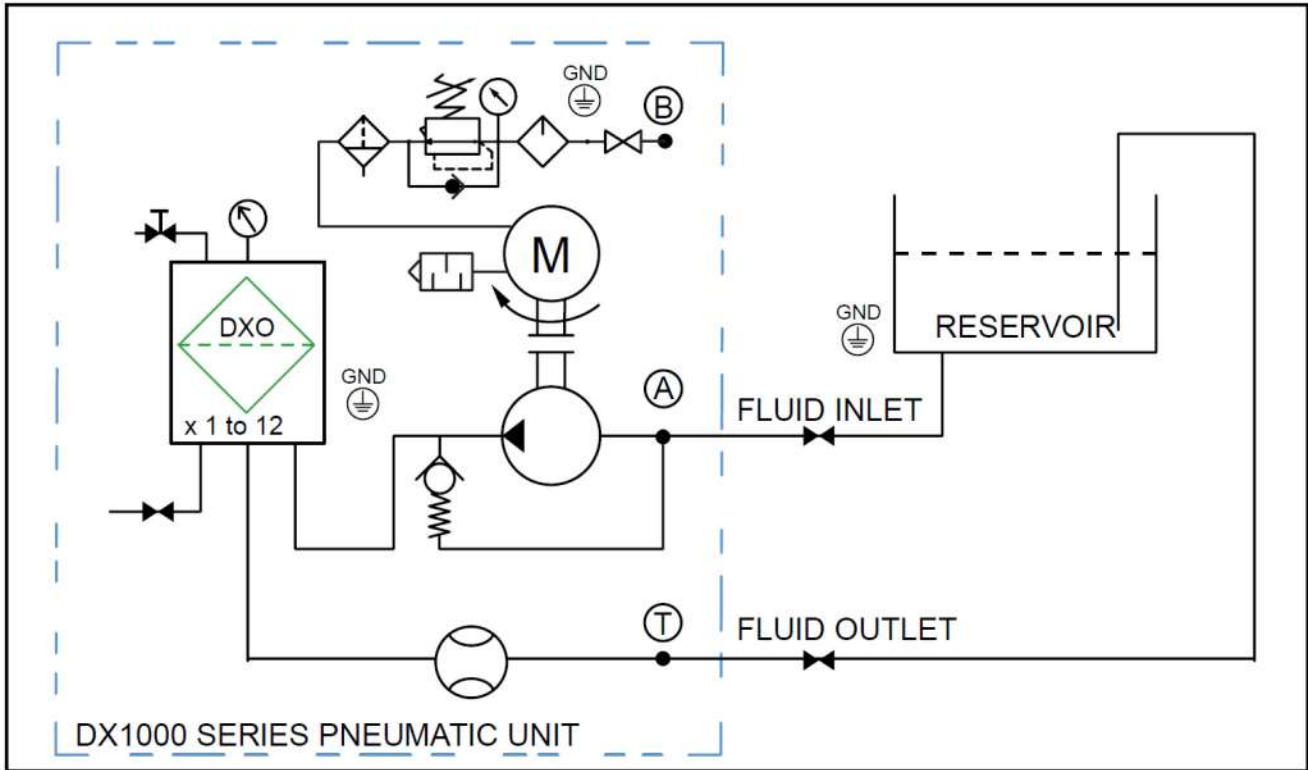

Motor	Pneumatic driven vane motor, EX class: II 2 GDc T4 (+10 °C < Ta < +40 °C)							
Max. Pressure [Barg]	Fluid Pressure 7 barg max /Air supply 7 Barg max							
Pump & Connection Ports	Fluid cleaning side: 1/2" BSP in & 3/8" BSP Out. Air Regulator, drive supply: G1/4" BSP							
Flow Indicator	Visual							
Suggested System Volume	4500ltrs @ 32cSt							
Flow rate	Approx flow at 2.7 bar:	32 cSt	46 cSt	68 cSt	100 cSt	220 cSt	320 cSt	460 cSt
		1.25 l/min	1.0 l/min	0.8 l/min	0.6 l/min	0.4 l/min	0.2 l/min	0.1 l/min
	Oil Volume	4500ltrs	3500ltrs	3000ltrs	2400ltrs	1800ltrs	800ltrs	400ltrs
Micron Rating	0.1 Micron							
Weight	25kg							
Measure [mm]	H 656 x D 369 x L 550							
Material	SS316							
DXO Cartridge	1							



ایران - تهران - خیابان پاسداران بیست و هشتم
 پلاک ۱ - برج آبتین، طبقه ۴ - واحد ۹
 شماره تماس: ۰۲۱ ۷۳۶۴۰۰۰
info@rnaco.com



General Arrangement

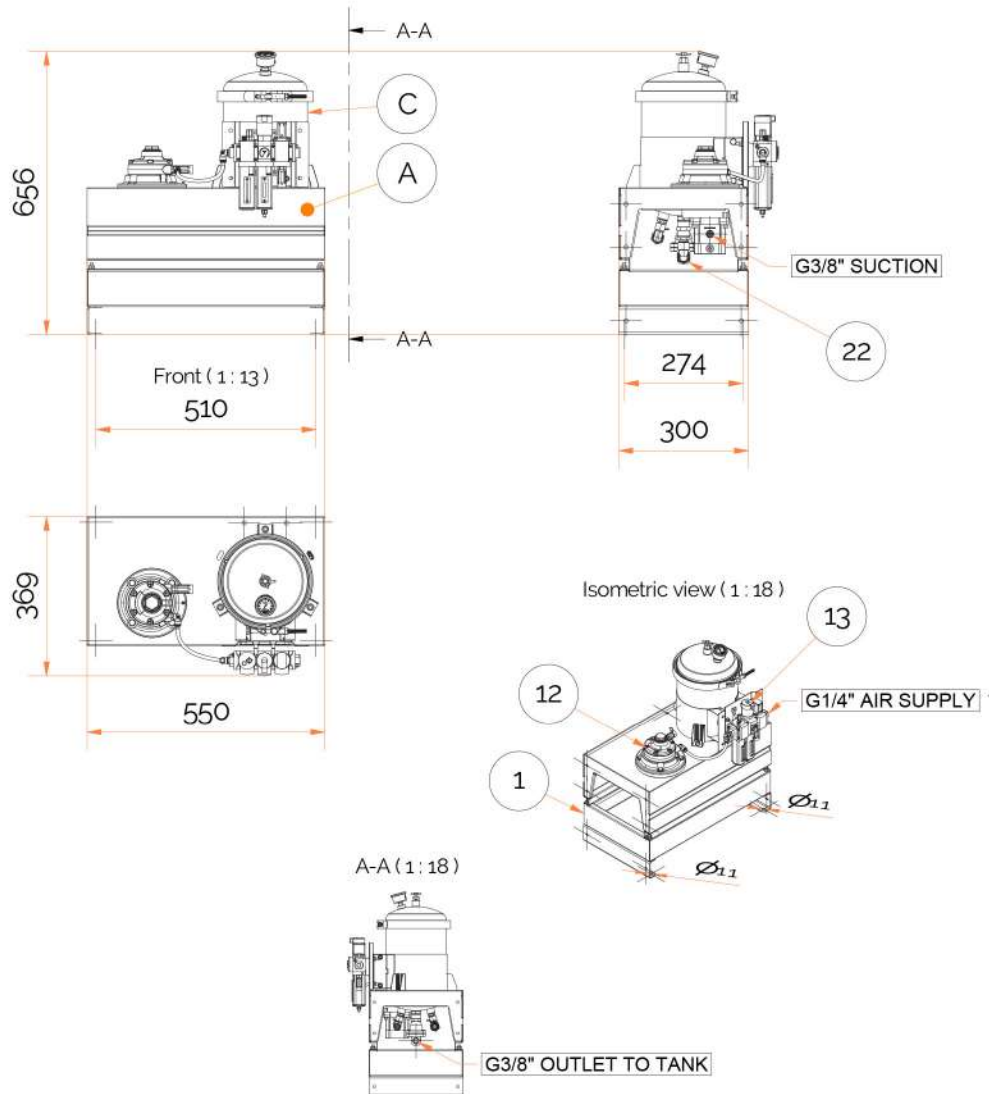

ایران - تهران - خیابان پاسداران بیستون هشتم
پلاک ۱ - برج آبتین، طبقه ۴ - واحد ۹
شماره تماس: ۰۲۱ ۷۳۶۴۰۰۰
info@rnaco.com