



DELTA-XERO

THE FUTURE IS SYSTEM RELIABILITY

DX1003-T-C-PT

The modern, eco-friendly solution to fluid conditioning for gas engines

The DX modular housing arrangement offers a flexible and space conscious solution to integrate our innovative DXO Powertrain Cartridge. The Delta-Xero Powertrain system can be configured up to 12 cartridges in parallel as a single unit in a compact and easily maintainable layout.

The unit can be supplied with a number of standard options to provide an effective fluid conditioning and monitoring package to suit the majority of systems. The flexibility of the unit allows tailoring to customer's specific requirements.



DX1003-T-PT

Drive Input	Electric
Connection Ports	1/2" BSP In & 3/4" Out
Flow Indicator	Visual
Flow Rate	Starting from 6lpm - varies per application
Particulate Removal	From 0,1 μm
Weight	45 Kg
Dimensions	H 1161 mm x D 472 mm x L 890 mm
Material	SS316
DXPT Cartridge QTY	3

© 2022 Delta-Xero All Rights Reserved. All information contained in this publication is indicative only and may be subject to change without prior notice.



ایران - تهران - خیابان پاسداران بیست و هشتم
پلاک ۱ - برج آبتین، طبقه ۴ - واحد ۹
شماره تماس: ۰۲۱ ۷۳۶۴۰۰۰
info@rnaco.com



نماینده فروش و خدمات پس از فروش DELTA-XERO در ایران



DELTA-XERO

THE FUTURE IS SYSTEM RELIABILITY

General Arrangement

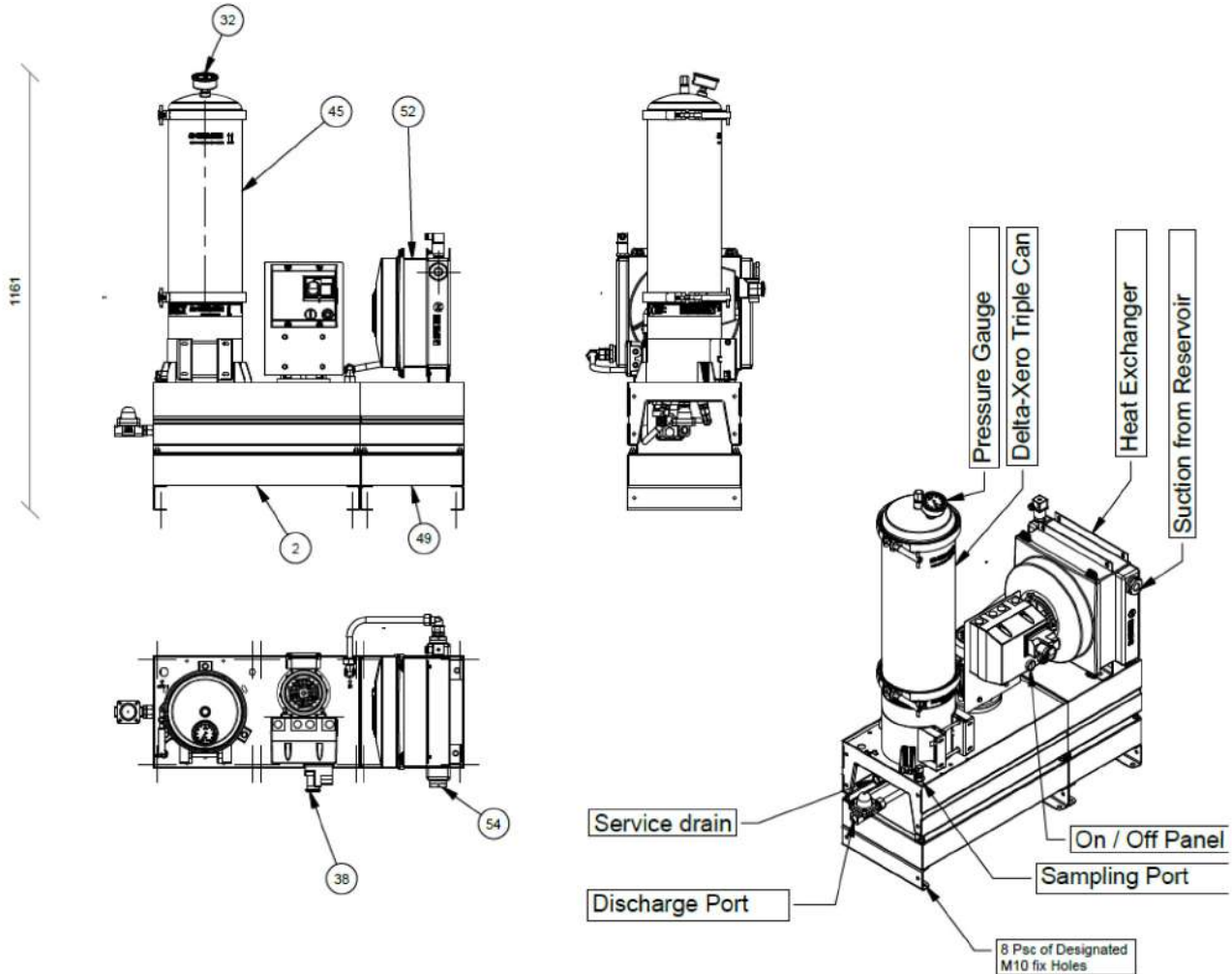

© 2022 Delta-Xero All Rights Reserved. All information contained in this publication is indicative only and may be subject to change without prior notice.



ایران - تهران - خیابان پاسداران بیست و هشتم
پلاک ۱ - برج آبتین، طبقه ۴ - واحد ۹
شماره تماس: ۰۲۱ ۷۳۶۴۰۰۰
info@rnaco.com



نماینده فروش و خدمات پس از فروش DELTA-XERO در ایران