



# DELTA-XERO

THE FUTURE IS SYSTEM RELIABILITY

## DX-1003-W

The DX modular housing arrangement offers a flexible and space conscious solution to integrate our innovative DXO Cartridge in to both new and existing systems. The Delta-Xero system can be configured up to 3 cartridges in parallel as a single unit in a compact and easily maintainable layout.

The unit can be supplied with a number of standard options to provide an effective fluid conditioning and monitoring package to suit the majority of systems. The flexibility of the unit allows tailoring to customer's specific requirements.



### DX1003-W

Drive Input	Electric or Pneumatic
Connection Ports	3/8" BSP In & Out
Flow Indicator	Visual
Suggested System Volume	Up to 13,500l @ 32cSt
Particulate Removal	From 0.1 µ
Weight	20 kg
Measure	H 1008 mm x D 261 mm x L 442 mm
Material	SS316
DXO Cartridge QTY	3

Flow Rate varies depending on viscosity, pressure and temperature

Approx flow at 2.7 bar:	32 cSt	46 cSt	68 cSt	100 cSt	220 cSt	320 cSt	460 cSt
	3.75 L/min	3.0 L/min	2.4 L/min	1.8 L/min	1.2 L/min	0.6 L/min	0.3 L/min
Oil Volume	13500ltrs	10500ltrs	9000ltrs	7200ltrs	5400ltrs	2400ltrs	1200ltrs



ایران - تهران - خیابان پاسداران بهستان هشتم  
پلاک ۱ - برج آبتین، طبقه ۴ - واحد ۹  
شماره تماس: ۰۲۱ ۷۳۶۴۰۰۰  
info@rnaco.com



## General Arrangement

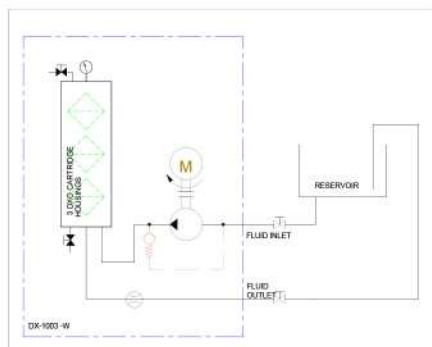
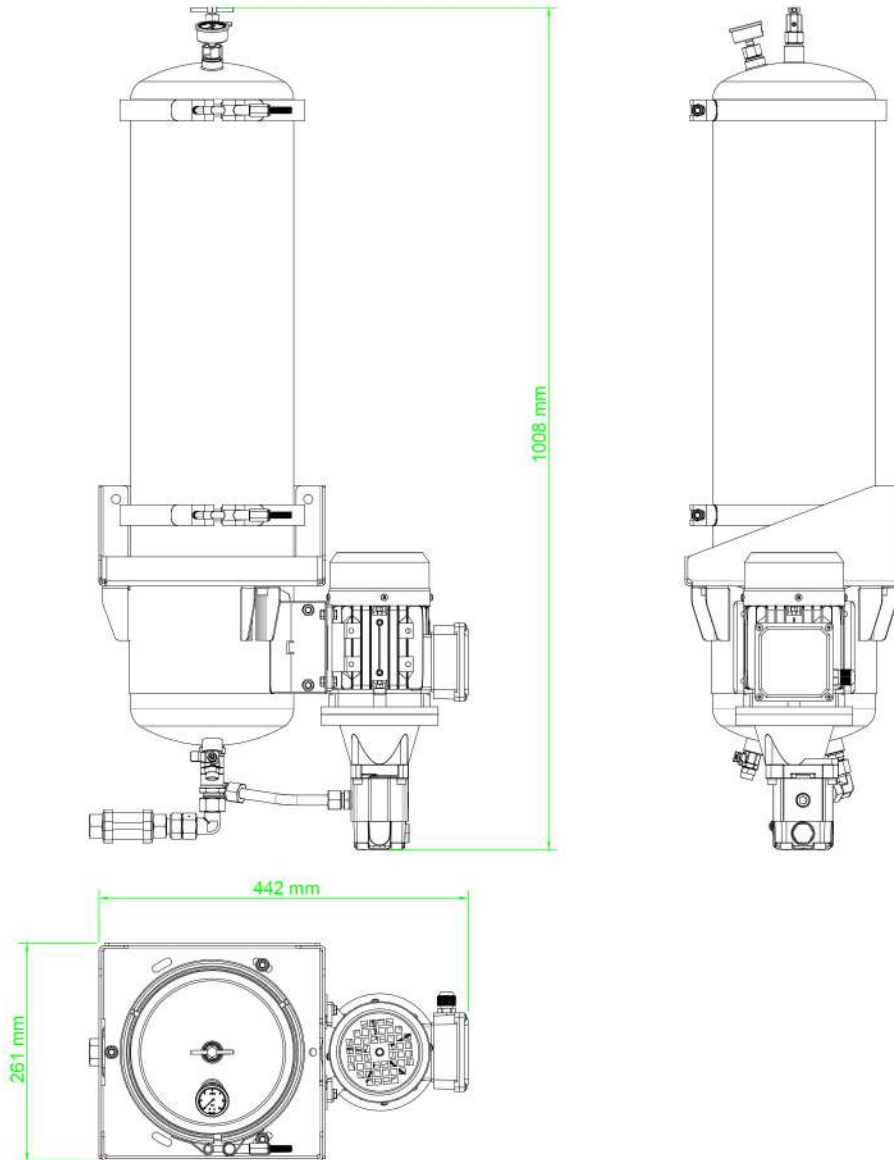

### DXO Cartridge

Contamination capacity:	Up to 4.5kg per DXO
Water absorption, free and bound:	2600ml
Material insert:	PP Cellulose mix



ایران - تهران - خیابان پاسداران بهستان هشتم  
پلاک ۱ - برج آبتین، طبقه ۴ - واحد ۹  
شماره تماس: ۰۲۱ ۷۳۶۴۰۰۰  
info@rnaco.com