



DX1525-PT

The modern, eco-friendly solution to fluid conditioning for Diesel

The DX1525 system has been designed to be our most compact and cost effective fluid conditioning unit on offer.

Engineered to fill a gap in our product offerings for smaller volume systems the DX1525 is ideal for keeping diesel and kerosene in reservoirs from 1000 litres in optimum health,

With emissions from engines becoming ever more important and the need to minimise engine O&M costs, the Delta-Xero PT systems for fuel polishing will deliver both in one low cost easy to install package with rapid return on investment.

The DX1525 is supplied with Pushbutton Sample and Visual Flow Indicator to provide an effective fluid conditioning system.

These units come both floor and wall mountable.



DX1525

Drive Input	Electric
Connection Ports	3/8" BSP In & Out
Flow Indicator	Visual
Suggested System Volume	4,000-5,000 ltrs - Fluid dependant
Flow Rate	Starting from 2.4 lpm
Particulate Removal	From 0.1 μ
Weight	13 kg
Dimensions	H 386 mm x D 230 mm x L 435 mm
Material	SS304, 316 and Aluminum
DXO-1525 Cartridge QTY	1



ایران - تهران - خیابان پاسداران پستمان هشتم
پلاک ۱ - برج آبتین، طبقه ۴ - واحد ۹
شماره تماس: ۰۲۱ ۷۳۶۴۰۰۰
info@rnaco.com



General Arrangement + Schematic

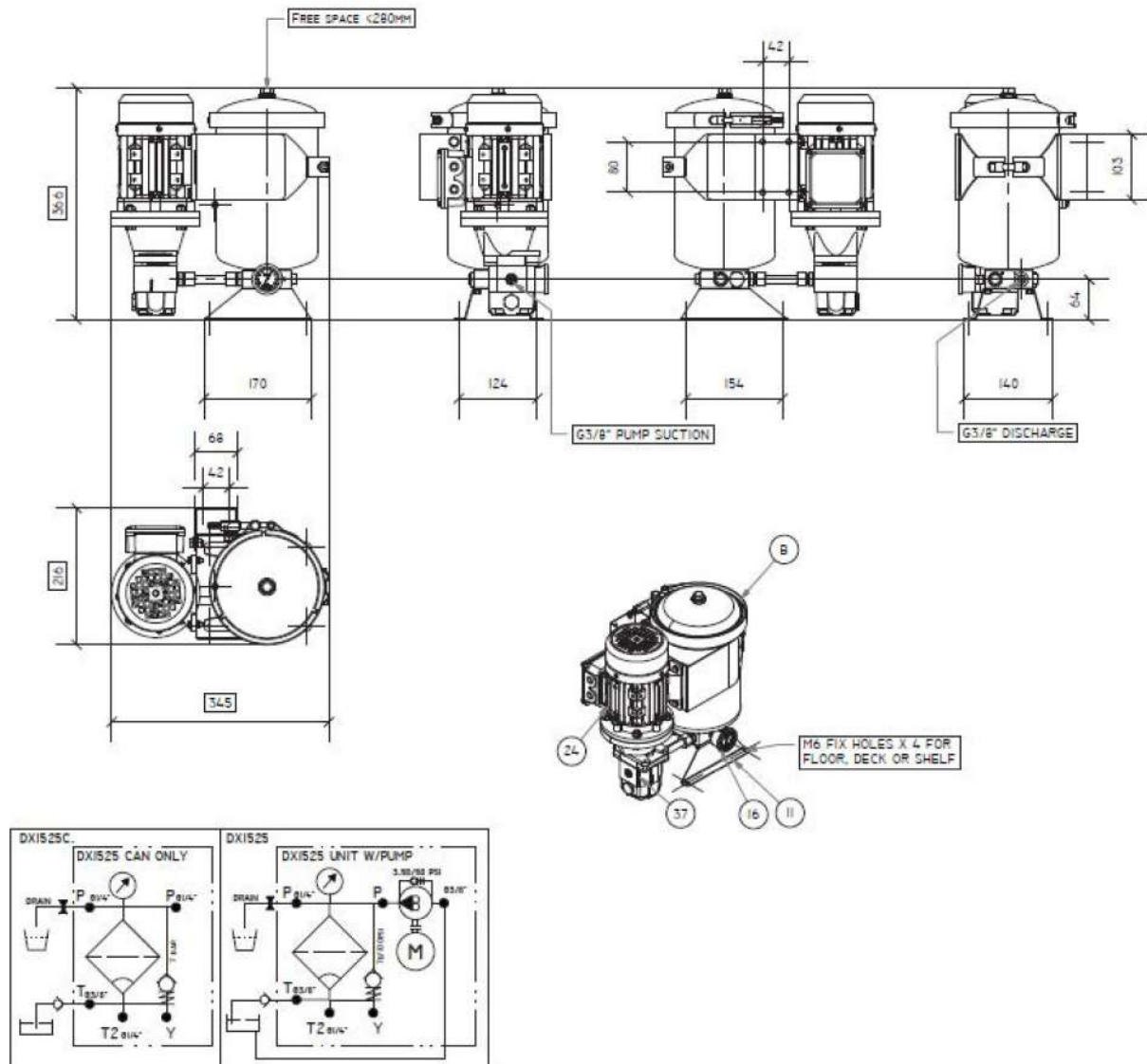

Cartridge Data: DXO-1525

Contaminated weight:	Up to 2.6Kg per DXO-1525
Water holding capacity, free and bound:	Approx. 800ml
Material insert:	PP Cellulose mix



ایران - تهران - خیابان پاسداران بهستان هشتم
پلاک ۱ - برج آبتین، طبقه ۴ - واحد ۹
شماره تماس: ۰۲۱ ۷۳۶۴۰۰۰
info@rnaco.com