



DELTA-XERO

THE FUTURE IS SYSTEM RELIABILITY

DX1006-T-PT-C

The modern, eco-friendly solution to fluid conditioning for landfill gas engines

The DX modular housing arrangement offers a flexible and space conscious solution to integrate our innovative DXO Powertrain Cartridge. The Delta-Xero Powertrain system can be configured up to 12 cartridges in parallel as a single unit in a compact and easily maintainable layout.

The unit can be supplied with a number of standard options to provide an effective fluid conditioning and monitoring package to suit the majority of systems. The flexibility of the unit allows tailoring to customer's specific requirements.



DX1006-T-PT

Drive Input	Electric
Connection Ports	3/4" BSP In & 1/2" Out
Flow Indicator	Visual
Suggested System Volume	Up to 1200 ltrs
Flow Rate	Starting from 6lpm - varies per application
Particulate Removal	From 0.1 µm
Weight	90Kg
Dimensions	H 1158 mm x D 440 mm x L 1100 mm
Material	SS316
DXPT Cartridge QTY	6

© 2022 Delta-Xero All Rights Reserved. All information contained in this publication is indicative only and may be subject to change without prior notice.



ایران - تهران - خیابان پاسداران پستستان هشتم
پلاک ۱ - برج آبتین، طبقه ۴ - واحد ۹
شماره تماس: ۰۲۱ ۷۳۶۴۰۰۰
info@rnaco.com



نماینده فروش و خدمات پس از فروش DELTA-XERO در ایران



DELTA-XERO

THE FUTURE IS SYSTEM RELIABILITY

General Arrangement

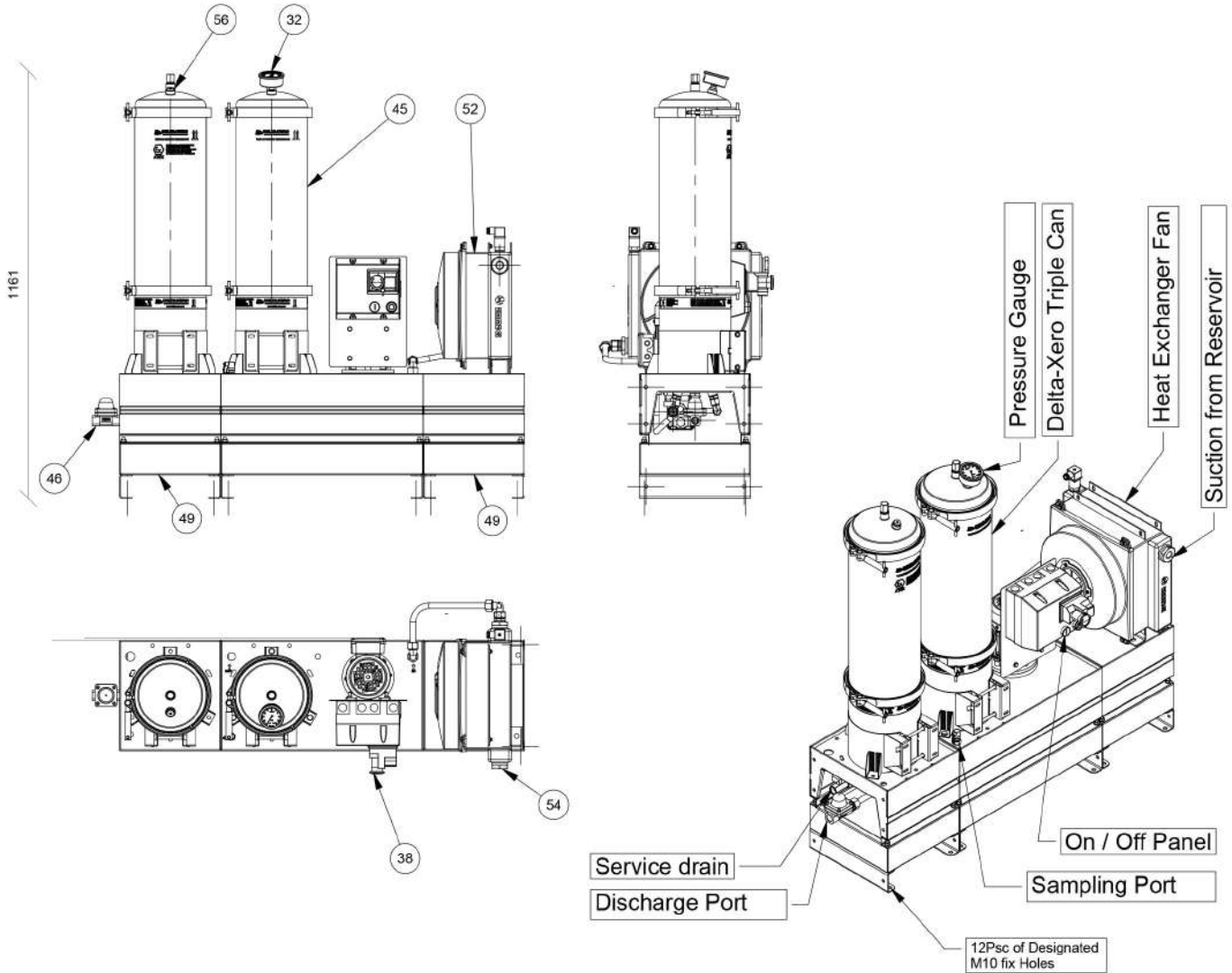

© 2022 Delta-Xero All Rights Reserved. All information contained in this publication is indicative only and may be subject to change without prior notice.



ایران - تهران - خیابان پاسداران بهستان هشتم
پلاک ۱ - برج آبتین، طبقه ۴ - واحد ۹
شماره تماس: ۰۲۱ ۷۳۶۴۰۰۰
info@rnaco.com



نماینده فروش و خدمات پس از فروش DELTA-XERO در ایران